



One-Day Workshop



Written by Wayne Bennett and Darrel Crane



1

---

---

---

---

---



---

---

---

Introduction

- Captain Wayne Bennett (ret.)
- Owner of Disaster Survival Skills, LLC since 1991
- Retired Fire Department- 33 years
- Responded to over 65,000 emergencies
- CPR & First Aid Instructor- 31 years
- FEMA CERT Instructor- 20 years



2

---

---

---

---

---

---

---

---

Earthquake

- Drop
- Cover
- Hold-On



3

---

---

---

---

---

---

---

---

### Drop, Cover and Hold-On vs. Triangle of Life

- Triangle of Life
- Drop, Cover & Hold-On



**DISASTER SURVIVAL SKILLS**

4

---

---

---

---

---

---

---

---

### Evacuate

- LifeSavers
  - Airway
  - Bleeding
  - Shock
- Remove possible non-trapped
  - Be careful not to aggravate any injuries
- Assembly Area
  - Roll call



**DISASTER SURVIVAL SKILLS**

5

---

---

---

---

---

---

---

---

### S.E.M.S Standardized Emergency Management System

- Mandated by Law
  - Standardized
- Emergency Scene Management
  - Efficient
- Large or Small Emergencies
  - Effective

**DISASTER SURVIVAL SKILLS**

6

---

---

---

---

---

---

---

---

## SEMS

standardized emergency management system

```

graph TD
    IC[Incident Commander] --> Ops[Operations]
    IC --> Plan[Planning]
    IC --> Log[Logistics]
    IC --> Fin[Finance]
    Ops --> SR[Search & Rescue]
    Ops --> Med[Medical]
    Plan --> Res[Resources]
    Plan --> Doc[Documentation]
    Log --> Supp[Supplies]
    Log --> Shelter[Shelter]
    Fin --> Payroll[Payroll]
    Fin --> Claims[Claims]
    
```

**Incident Commander**- Responsible for overall development, implementation and management of the plan. Ordering and releasing of resources.

**Operations**- Responsible for carrying out the response side of the plan. Coordinates and directs all efforts of the Search & Rescue, Medical Groups, etc.

**Planning**- Responsible for collecting, evaluating and disseminating information regarding the incident and the status of resources available to deal with the incident.

**Logistics**- Responsible for facilities, services and materials needed to support the incident. This includes feeding and sheltering everyone.

**Finance**- Responsible for tracking hours worked by employees during the disaster. Maintaining records of any monies spent to support the incident.

7

---

---

---

---

---

---

---

---

---

---

## Creating an Emergency Response Team

- **Incident Commander**  
Responsible for the entire site  
Determines the priorities and coordinates the effort
- **Group Supervisor**  
Manager, no hands-on  
Manages teams to accomplish single task  
Reports directly to Incident Commander
- **Team Leader**  
Supervises the team  
Reports directly to Group Supervisor

8

---

---

---

---

---

---

---

---

---

---

## Emergency Response Team Responsibilities

- Perform LifeSavers
- Communications and Documentation
- Fire Control & Hazard Control
- Flexible
- Common Sense

9

---

---

---

---

---

---

---

---

---

---

### Heavy Urban Search & Rescue

- This situation will require heavy rescue teams with specialized tools and training. Only about 15% of the affected area will involve structural collapse. Realize some situations will be beyond your



10

---

---

---

---

---

---

---

---

### Residential Collapse



11

---

---

---

---

---

---

---

---

### School Collapse



12

---

---

---

---

---

---

---

---

School Collapse



**DISASTER SURVIVAL SKILLS**

13

---

---

---

---

---

---

---

---

School Damage



**DISASTER SURVIVAL SKILLS**

14

---

---

---

---

---

---

---

---

Leaning of a Structure



**DISASTER SURVIVAL SKILLS**

15

---

---

---

---



---

---

---

---

### Large Cracks



16

---

---

---

---

---



---

---

---

### Light Urban Search & Rescue

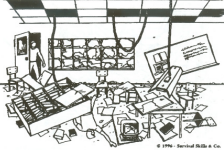
- Non-structural collapse and interior furnishings will become the hazards, causing injuries and entrapment. Although not as serious as structural collapse, it could amount to 80-90% of the rescue situations.



17

---

---

---

---

---



---

---

---

### Light Urban Search & Rescue Objectives

- Locate victims  
Avoid sweeps, use roll call  
Perform LifeSavers
- Removal of victims-not bodies  
Remove non-trapped victims first
- Status Report  
Ongoing written record of events  
Damage assessment  
Turn in to Group Supervisor



18

---

---

---

---

---

---

---

---

## Light Urban Search & Rescue Responsibilities

- Safety
  - Yourself
  - Your Team
  - The Victims
- Team assignments
  - Rescue known victim locations first
- Know your rescue equipment
  - Train with realism
  - Annual inventories



19

---

---

---

---

---

---



---

---

## Building Size-up

The quick "walk the block" (size-up) could provide you a view of up to 75% of your assigned search area by looking in exterior doors and windows.

- "Walk the Block"
  - See all **four** sides
  - Every building
- Create Status Report
  - Includes victim and building conditions
  - Turn into Group Supervisor
- Group Supervisor creates rescue plan
  - Based on priorities
  - Number of victims and condition
  - Location, hazards and available rescuers



20

---

---

---

---

---

---



---

---

## Building Entry

We are ready to enter the building. Or are we? Don't forget to check the doors to see if doors are "HOT"

- Are you prepared?
  - Proper clothing and equipment
  - Rescue plan with clear objectives
- Select a safe entrance
  - Your "walk the block" will accomplish this
  - Check all doors for hazards before entering
- Gaining access
  - Examine for easiest and safest entry and exit
  - Try simple techniques for jammed doors



21

---

---

---

---

---

---

---

---

### Forcible Entry-Doors

- Simple mechanical advantage
  - Prying leverage will work on wood or metal door frames.
  - And of course, always "Try before you pry"

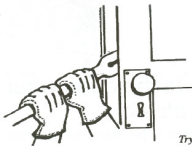

*Try before you pry*

**DISASTER SURVIVAL SKILLS**

22

---

---

---

---

---

---

---

---

### Forcible Entry- Windows

Windows are a second way in. Secure the glass before breaking.

- Like doors, try to open first
- Three types of glass
  - Plate glass
  - Tempered glass
  - Plexiglas
- Use safe techniques when breaking glass
  - What appears to be the quickest, may take the longest.



**DISASTER SURVIVAL SKILLS**

23

---

---

---

---

---

---

---

---

### Interior Search Methods

- Mark the main entrance with a slash, date and time.
- Search
  - Visually**
  - Vocally**
  - Physically**
- Follow the wall (to the right) during search
  - Systematic search covering every square foot.

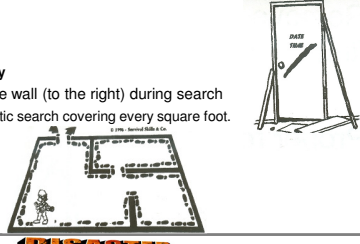

**DISASTER SURVIVAL SKILLS**

24

---

---

---

---

---

---

---

---



### Interior Search Methods

- Remove non-trapped victims first
- Proper removal of trapped victims
- Exit room-complete "X"



© 1996 - Survival Skills & Co.

**DISASTER SURVIVAL SKILLS**

25

---

---

---

---

---

---

---

---

### Victim Removal-Standing Carry



© 1996 - Survival Skills & Co. © 1996 - Survival Skills & Co.

**DISASTER SURVIVAL SKILLS**

26

---

---

---

---

---

---

---

---

### Chair Carry

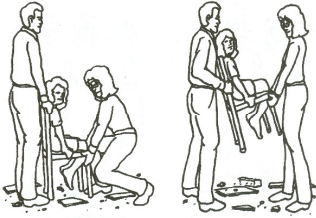

© 1996 - Survival Skills & Co.

**DISASTER SURVIVAL SKILLS**

27

---

---

---

---

---

---

---

---

### Drags

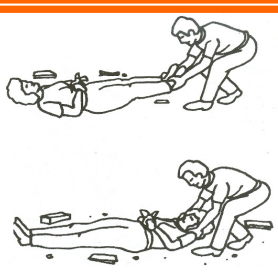

**DISASTER SURVIVAL SKILLS**

28

---

---

---

---

---

---

---

---

### Stretcher Carry

- Feet next to stretcher
- Bend knees, not back
- Lift together on the count of 3
- The rescuer at the head of the patient is in charge



**DISASTER SURVIVAL SKILLS**

29

---

---

---

---

---

---

---

---

### Mechanical Advantage

The further away you are from the load, the less effort required. A minimum length of a four foot lever is recommended.

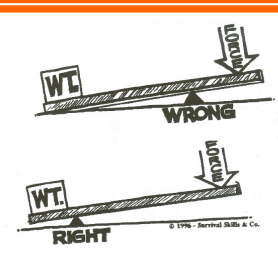

**DISASTER SURVIVAL SKILLS**

30

---

---

---

---

---

---

---

---

### Mechanical Advantage

- The Fulcrum



Stability



Strength

- The bottom lever of the same length will lift more weight before breaking



31

---

---

---

---

---

---

---

---

### Cribbing (Stabilization)

- Support any corner not touching the ground.
- Cribbing must be even on two sides and won't collapse under weight.
- Regardless of lifting device, always stabilize with cribbing.

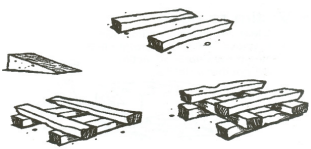

32

---

---

---

---

---

---

---

---

### Light Rescue

- Stabilize corners first with cribbing  
Build using a wide base for stability  
Use wedges to fill in gaps
- Lifting technique  
Place fulcrum in center of object while cribbing  
Push down-using lever and fulcrum, not your back  
Lift an inch, crib an inch
- Victim removal  
Clear debris from victims' path  
Remove victim in a straight line  
Never roll debris off victim  
Do not throw debris

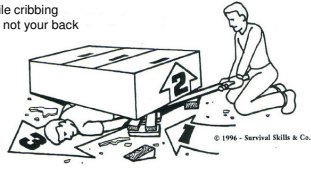

© 1996 - Survival Skills & Co.



33

---

---

---

---

---

---

---

---